

1. ALL DIMENSIONS ARE IN METERS UNLESS OTHERWISE STATED.
2. FOR DETAILS OF PAVEMENT LAYERS AND SURFACING SEE PAVEMENT DETAIL SHEET
3. TOP OF THE SOFT SHOULDER CAN BE PAVED WITH BITUMEN MIXTURE TO AVOID WASHOUT OF THE SHOULDER INSTEAD OF SHOULDER FILL.
4. FOR DETAILS OF CONSTRUCTION TO WIDENING AND CONSTRUCTION SEQUENCE SEE DWG. NO. NHSP/G-04
5. IN RESTRICTED WIDTH AREAS OR AS DIRECTED AT SITE, EARTH DRAIN TO BE REPLACED WITH BUILT DRAIN.
6. SURFACING SHALL BE AS DETAILED ON PAVEMENT DETAIL SHEET SHOULDERS SHALL BE AS DETERMINED ON SITE TO SUIT LOCAL CONDITIONS AND EXISTING ROW.
7. FOR DETAILS OF BENCHING AND FILL OVER MARSHY AREAS SEE DWG. NO. NHSP/G-05
8. AT BUILT DRAIN LOCATIONS SURFACING SHALL BE CONTINUED ACROSS THE FULL WIDTH OF THE SHOULDER.
9. FOR DRAIN DETAILS SEE DWG. NO. NHSP/DS-01/1, NHSP/DS-01/2

**WIDENING & OVERLAY**

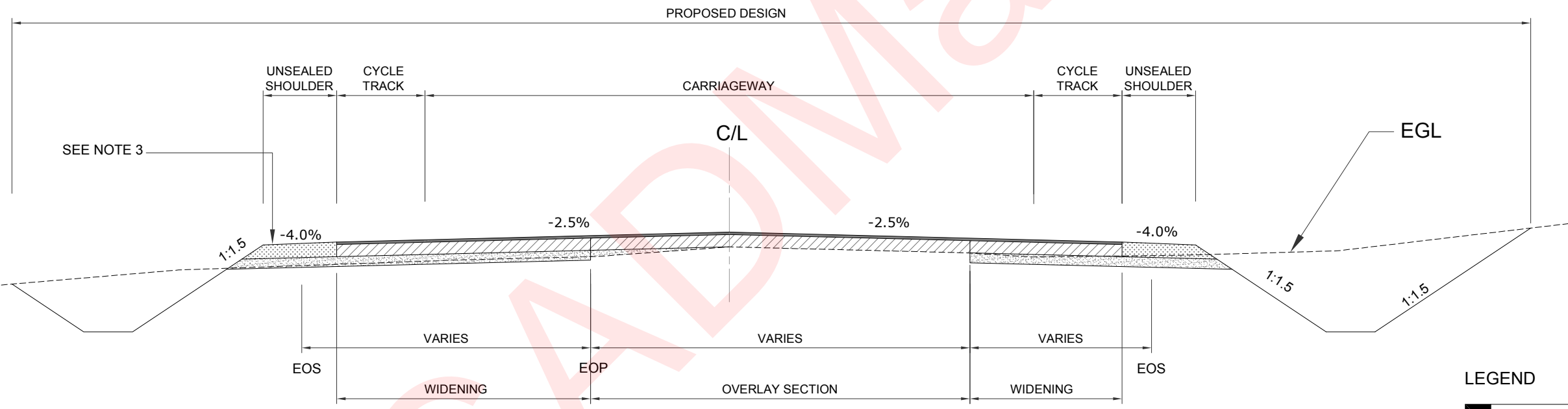

**WIDENING & OVERLAY ON RURAL FLAT TERRAIN**

**LEGEND**

	DOUBLE BITUMEN SURFACE TREATMENT	DBS <sup>†</sup>
	GRANULAR BASE - ABC / SEA SAND	GB
	GRANULAR SUB BASE	GS
	GRANULAR CAPPING	GC
	EMBANK.FILL - TYPE I	
	SHOULDER FILL	
	40mm BEDDING SAND	

# SUPERELEVATION DEVELOPMENT DIAGRAMS FOR CIRCULAR CURVES

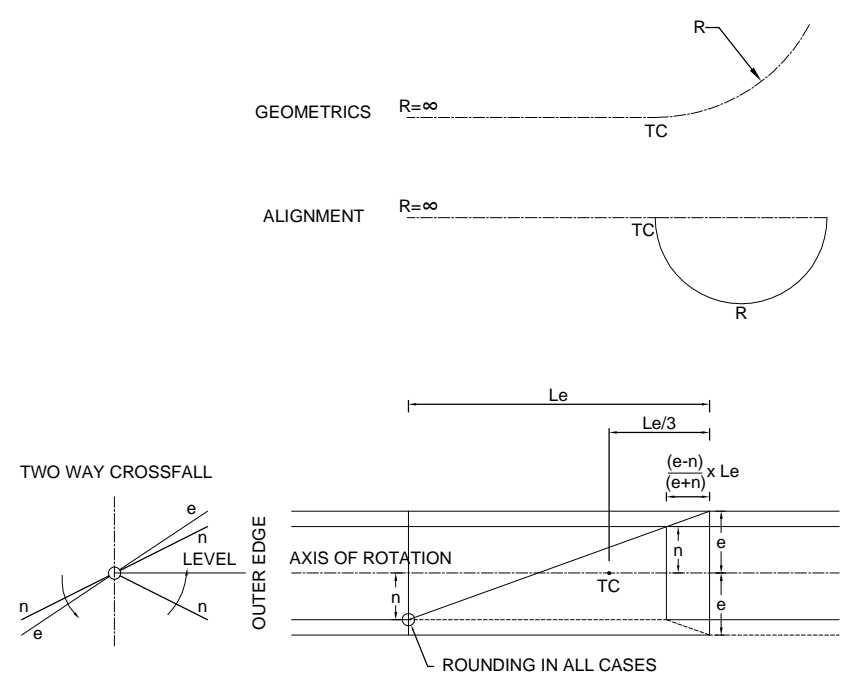

CASE 1. EDGE PROFILE - TANGENT TO CURVE

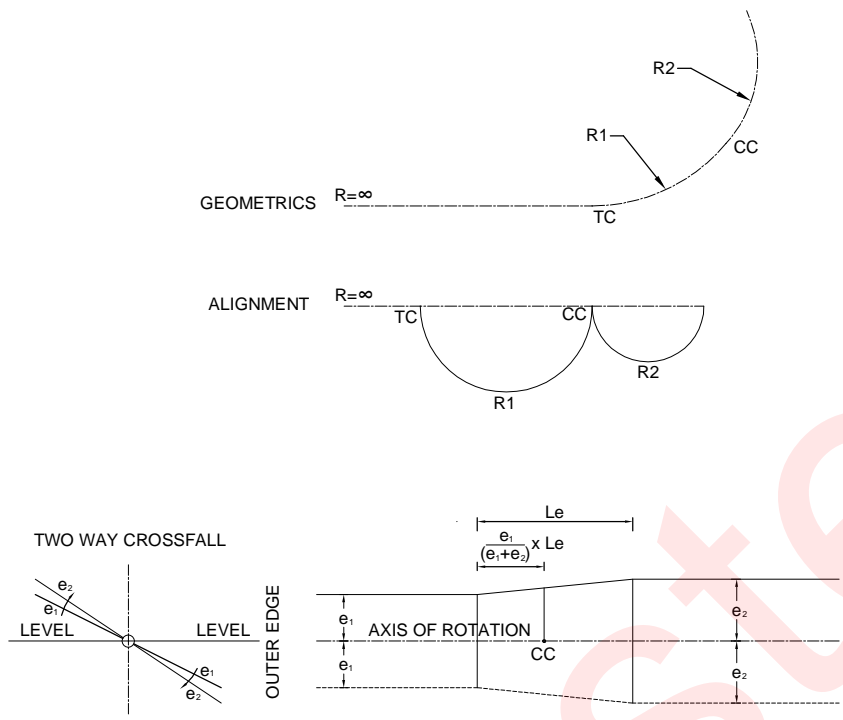

CASE 2. EDGE PROFILE - UNIDIRECTIONAL CURVES COMMON TANGENT POINT

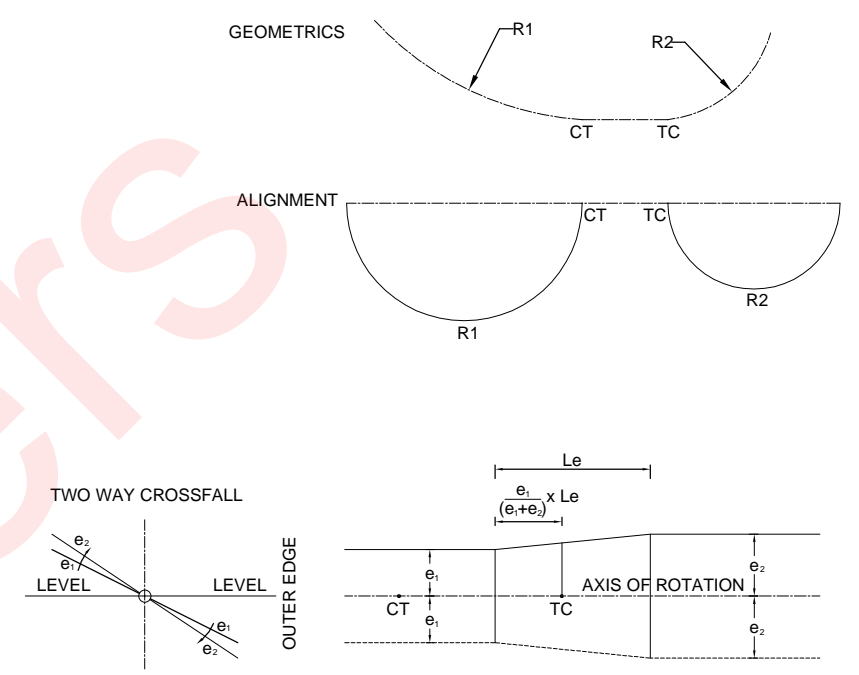

CASE 3. EDGE PROFILE - UNIDIRECTIONAL CURVES CLOSE TANGENT POINTS

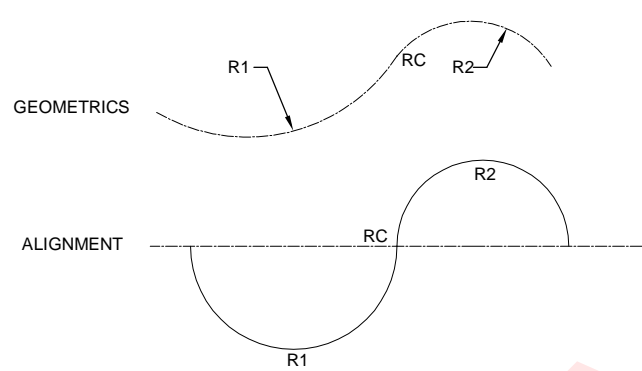

CASE 4. REVERSE CURVES COMMON TANGENT POINT

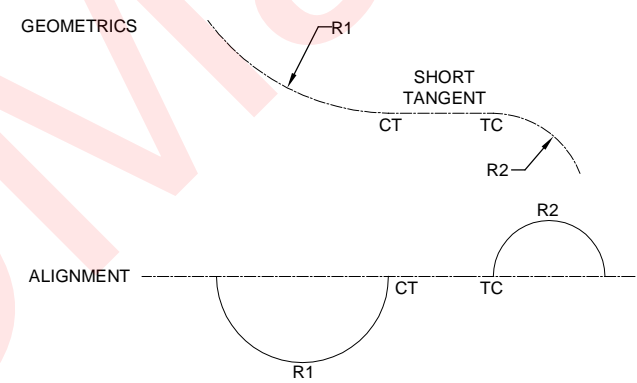

CASE 5. REVERSE CURVES CROSS TANGENT POINT

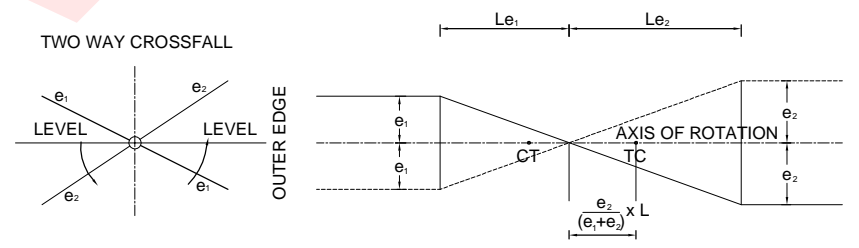
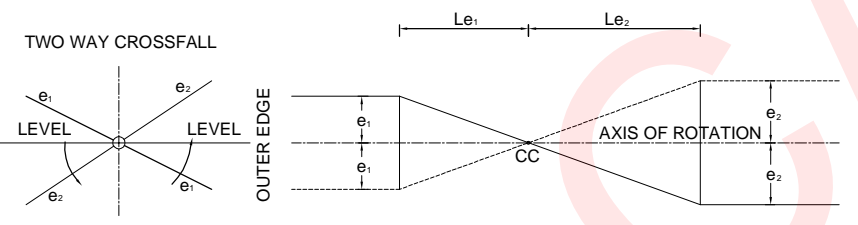

### LEGEND

- : CENTER OF ROADWAY
- : LEFT SIDE EDGE OF CARRIAGEWAY LOOKING UP CHAINAGE
- : RIGHT SIDE EDGE OF CARRIAGEWAY LOOKING UP CHAINAGE
  
- Le : LENGTH OF SUPERELEVATION DEVELOPMENT
- TC : TANGENT TO CIRCULAR CURVE POINT
- CT : CIRCULAR CURVE TO TANGENT POINT
- RC : POINT OF REVERSE CURVE
- CC : POINT OF COMPOUND CURVE
- e : SUPERELEVATION RATE
- R1, R2 : RADIUS OF CIRCULAR CURVE
- n : NORMAL CROSS FALL
- L : TC - CT

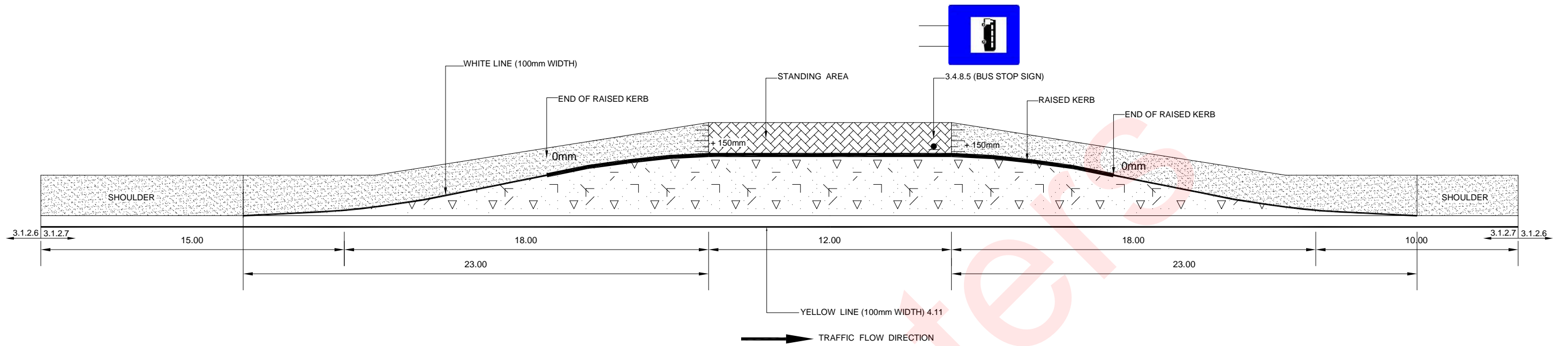

PLAN VIEW FOR BUS BAY

NOT TO SCALE

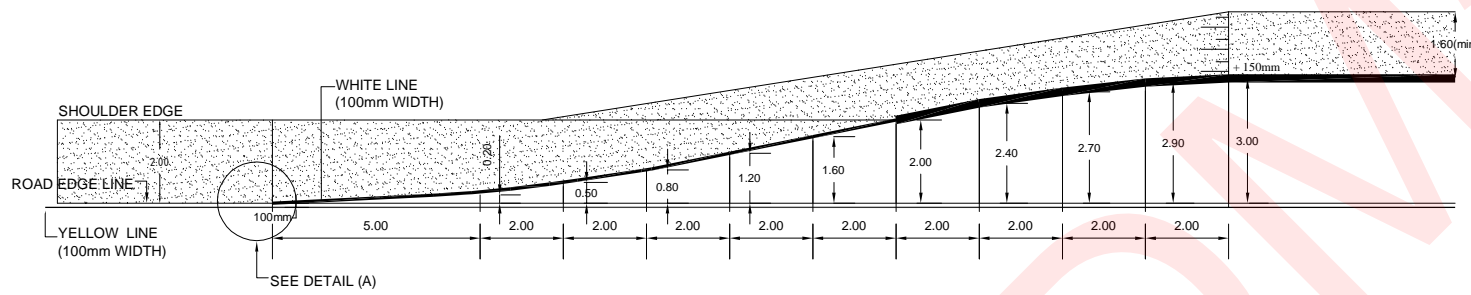

SETTING OUT DETAIL FOR BUS BAY

NOT TO SCALE

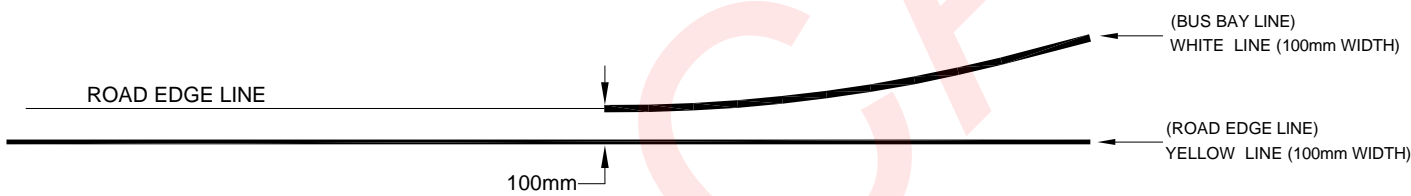

DETAIL (A)

NOT TO SCALE

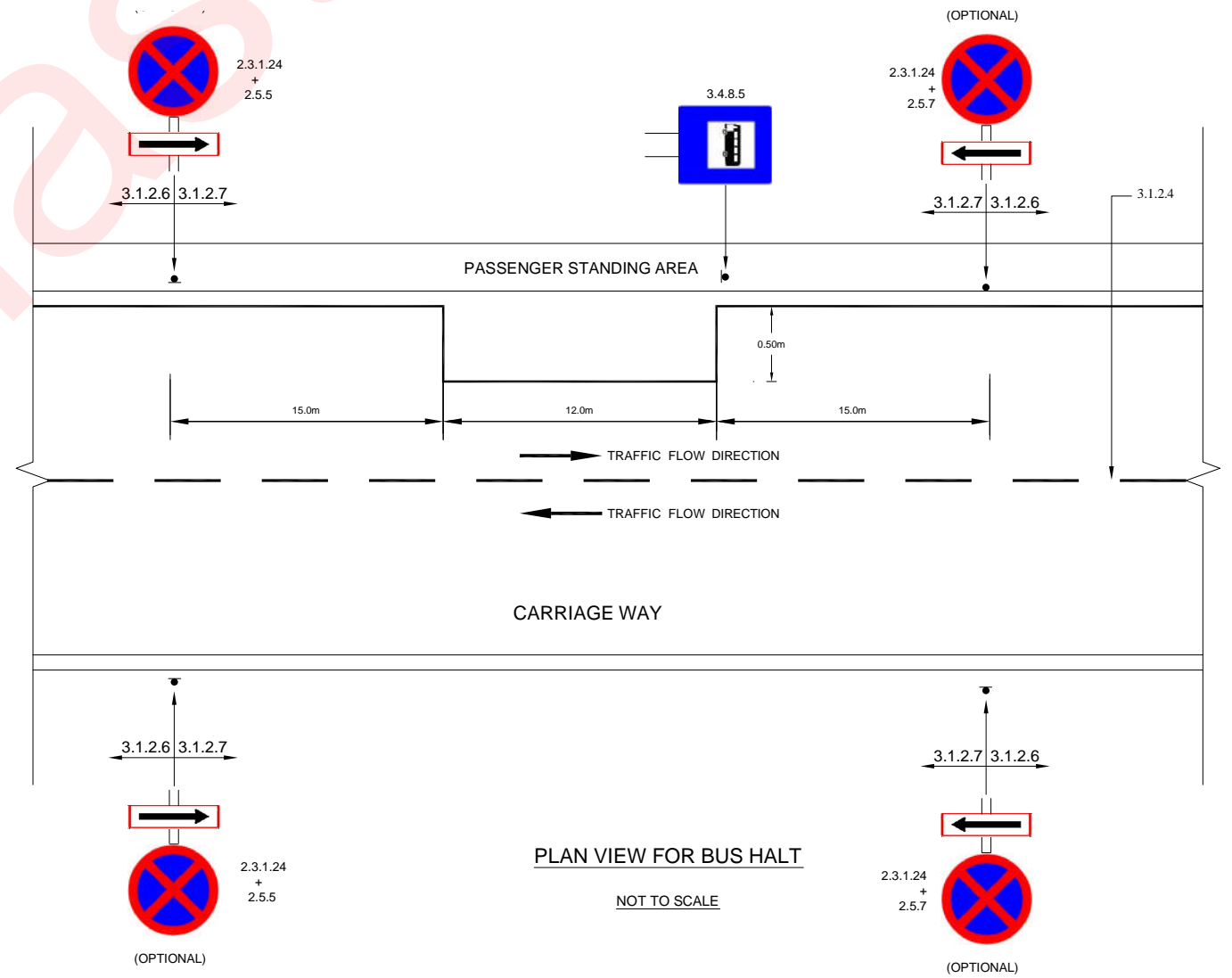

PLAN VIEW FOR BUS HALT

NOT TO SCALE

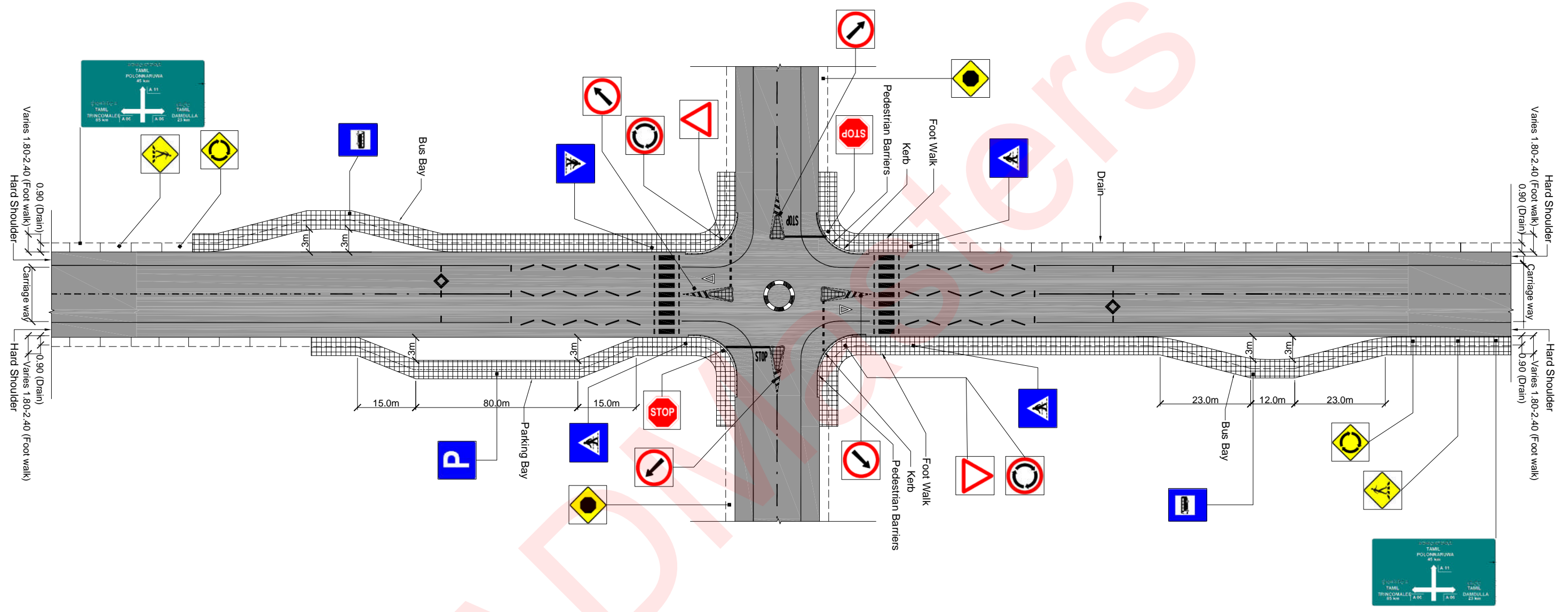

CADDERS

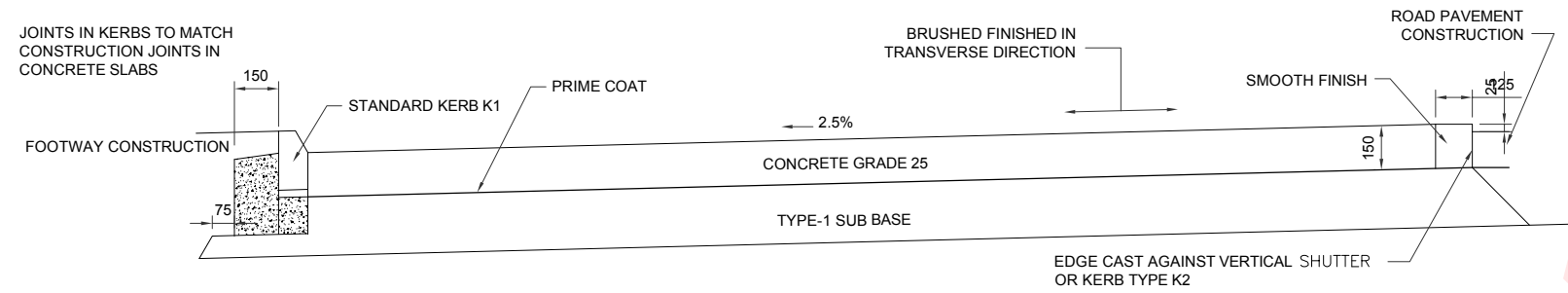

**SECTION THROUGH BUS BAY**  
SCALE: 1:25

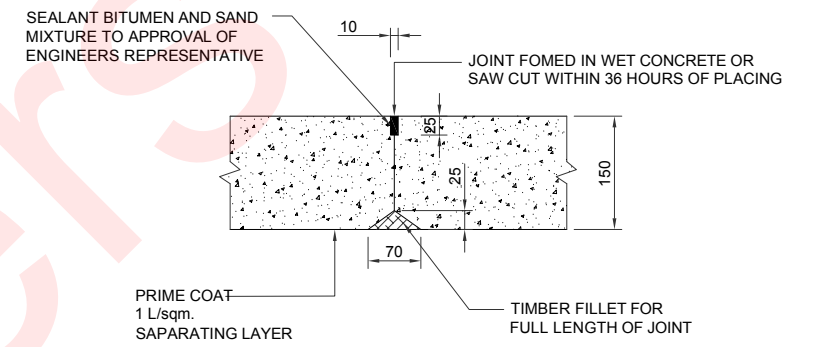

**CONCRETE CONTRACTION JOINT BUS BAYS AND PARKING BAYS**  
SCALE: 1:10

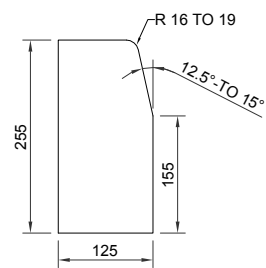

**BARRIER KERB**  
TYPE - K1

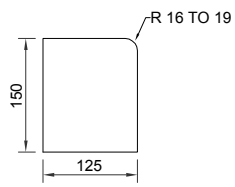

**DROPPED KERB**  
TYPE - K2

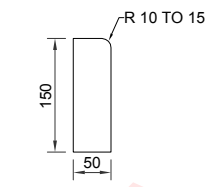

**CONCRETE EDGING**  
TYPE - E1

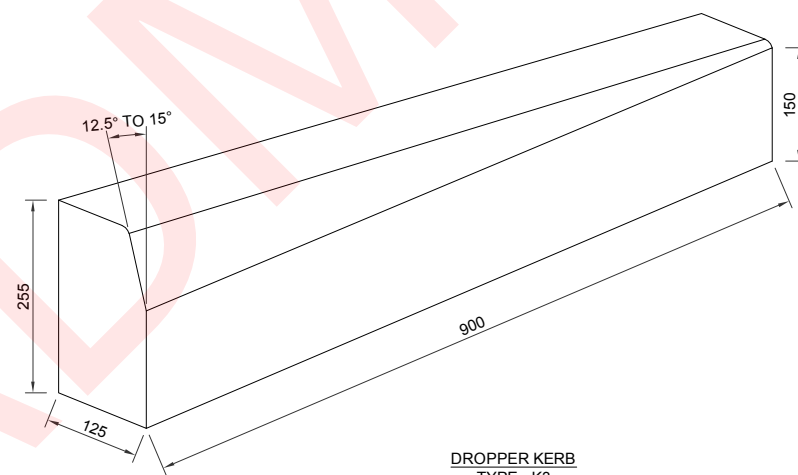

**DROPPER KERB**  
TYPE - K3

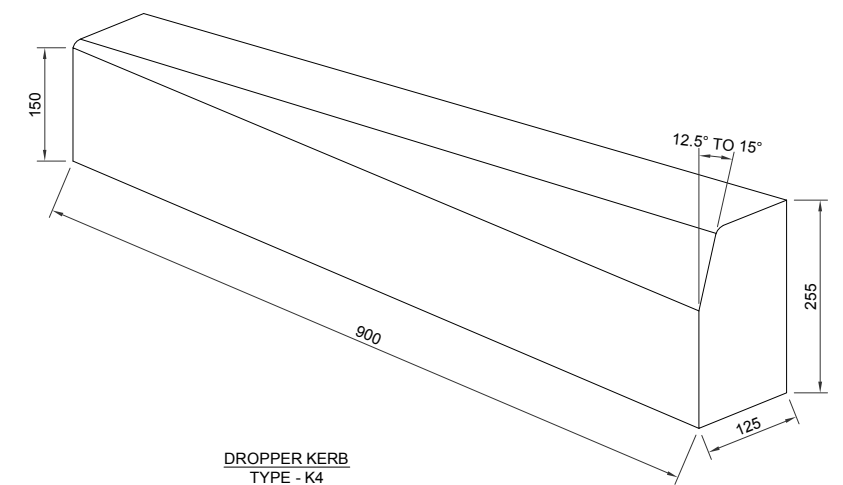

**DROPPER KERB**  
TYPE - K4

**DETAILS OF TYPICAL KERB STONES**  
SCALE: 1:10

**NOTES:**

1. GRADE 20(20) CONCRETE TO BE USED IN CASTING KERBS
2. MAXIMUM CASTING LENGTH 900mm
3. ALL DIMENSIONS ARE IN MILLIMETERS